

AC Output¹

28 kW	60 Hz, 1800 RPM, 3 Ph, 0.8 PF, 120/208V, 97A, opt.1 Ph: 240V, 117A
Optional	Single Phase with 1.0 PF
Voltage regulation	±1%

Lugger L944 Engine

Type	Vertical inline 4 cylinder diesel
Displacement	203 cubic in (3.33 ltr)
Bore/Stroke	3.70/4.72 in (94/120 mm)
HP @ RPM	46 @ 1800

Approx. fuel use

1800 RPM @ full load ²	2.5 gph (8.6 lph)
1800 RPM @ half load ²	1.5 gph (5.3 lph)

Installation Data & Weight

Exhaust outlet	2 inch (51mm)
Fuel inlet and return	1/4 inch NPT
Approximate dry weight	1316 lbs (600 kg)

- Deratings: 3% per 1000 ft. over 500 feet above sea level. 1.5% for every 10° over 77°F
- Actual fuel consumption will vary depending on operating conditions.

DIMENSIONAL DRAWING

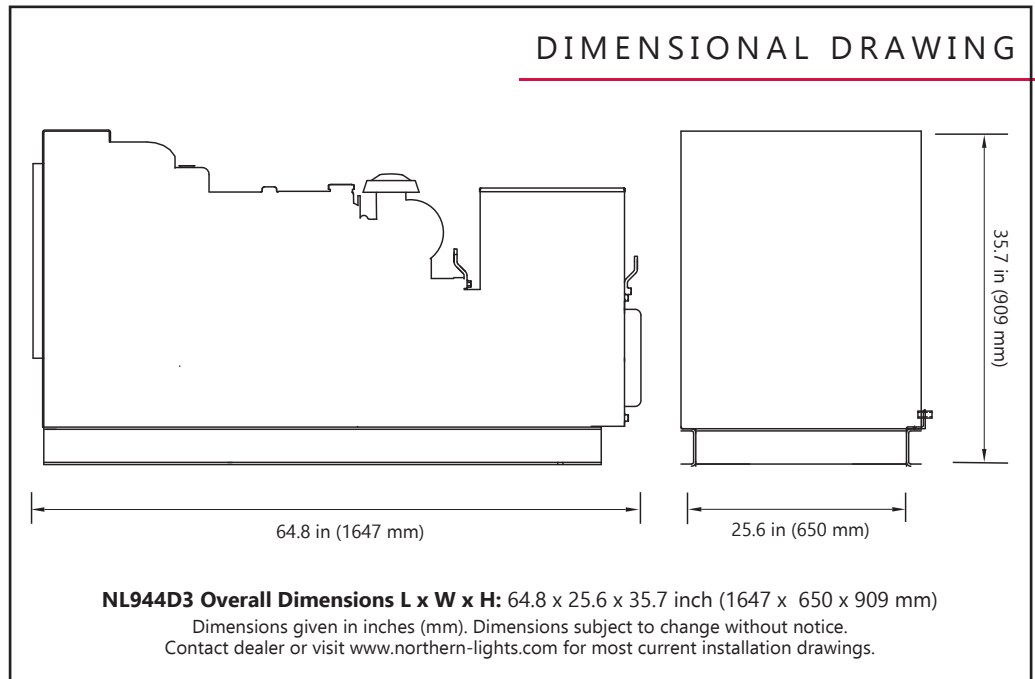

NL944D3 FEATURES AND BENEFITS

ENGINE BLOCK

- Lugger four cycle, 4 cylinder, liquid cooled, naturally aspirated, overhead valve industrial duty diesel engine block.
- 2 valves per cylinder.
- Double wall oil pan.
- Crankshaft is induction hardened, forged carbon steel; stronger than cast iron.
- Helical cut and ground carbon steel timing gears reduce noise.
- Cross flow head for efficient breathing.

COOLING SYSTEM

- Liquid cooled with radiator and pusher cooling fan. Radiator shroud and fan hand guard.

FUEL SYSTEM

- Indirect Injection with glow plugs.
- Bosch-type in-line injection pump with 5% mechanical governor for close AC output frequency control.
- Pintle type injectors.
- Mechanical fuel lift pump with hand primer.
- Large spin-on fuel filter.
- Flexible fuel lines routed to base.
- Stop solenoid controls fuel rack, not throttle, for fast engine shutdowns.

INTAKE AND EXHAUST

- Meets US EPA interim Tier IV emission requirements.
- Large air cleaner with replaceable filter element.

LUBRICATION SYSTEM

- Full flow, spin-on oil filter with bypass.

DC ELECTRICAL SYSTEM

- 12 volt starter and battery charging alternator with regulator.
- DC system uses reliable relays instead of unrepairable printed circuit boards.
- Standard panel: unit mounted S-1B has hour meter, shutdown bypass, stop-start switch and preheat switch.
- Expandable to six panels, 110 ft from set.
- Low oil pressure, high coolant temp shutdowns are standard.

AC GENERATOR

- Direct coupled, 4-pole, revolving field generator with Class H insulation and pre-lubricated, double sealed bearing. Brushless design is maintenance free. 12 lead-3 phase standard.
- Conservative heat rise rating of 95°F / 50°C, ideal for tropical applications and continuous operation.
- Automatic Voltage Regulator (AVR) gives quick +/-1% RMS no load to full load voltage regulation.
- High air flow from cast aluminum fan keeps generator running cool.
- Terminal strip in j-box for easy voltage changes and connection to AC distribution system.

SPECIAL EQUIPMENT

- Steel base frame provides rigid support and makes installation easy.
- Vibration mounts isolate engine vibration for smooth, quiet operation.
- Long life, Imron® enamel finish for excellent service visibility.
- Operator's and parts manuals standard. Optionally available on CD-ROM.
- Each set is test run with load.
- Industry-best, transferrable warranty.

NOTE: Tier III Standby Emergency Duty Only (See NL944T3 spec sheet)

**TIER
3**